

HUM8PV

Photovoltaic moulded case circuit breaker



1. Application

HUM8PV photovoltaic moulded case circuit breaker (hereinafter referred to as circuit breaker) is applied to the DC circuit with rated voltage up to DC1000 V, and rated current 16A to 690A. Featured with functions of overload long time delay protection and short circuit instantaneous protection, the product can distribute electric power, and protect the line and the equipment from being damaged due to overload, short circuit, and other failures. This product accords with the standard of IEC60947-2.



2. Normal operation conditions

1. Ambient temperature: $-25^{\circ}\text{C}\sim+70^{\circ}\text{C}$; average temperature within 24h: $\leq+35^{\circ}\text{C}$
2. Altitude: $\leq 2000\text{m}$
3. Humidity: The air relative humidity under the highest temperature $+40^{\circ}\text{C}$ cannot surpass 50%; Under the lowest temperature has a higher relative humidity, the wettest month's average lowest temperature cannot surpass $+25^{\circ}\text{C}$, and the average relative humidity cannot exceed 90%;
4. Pollution degree: class3
5. Mounted at places without explosive risk, without gases that may be corrosive to metal or gases that may cause damage to the insulation, and with little conducting dust
6. Mounting category: III



3. Model and meaning

1. Model and meaning

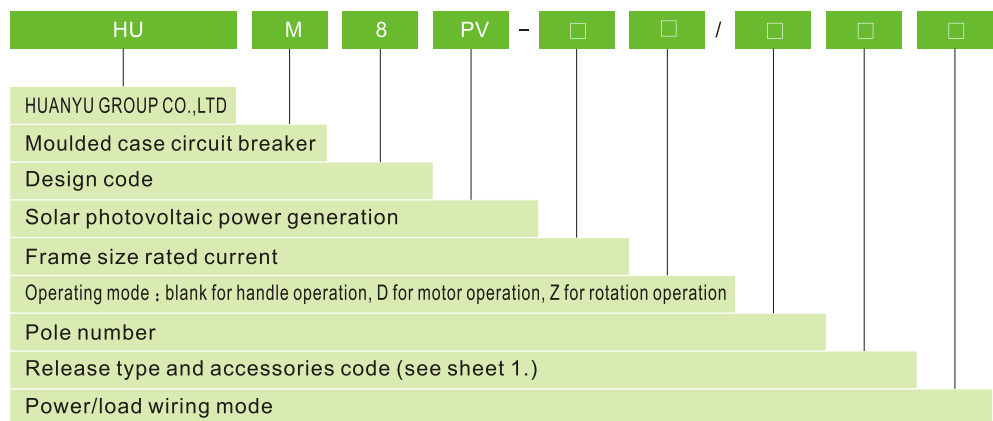

Sheet 1. Release type and accessories code

Accessories name	No accessories	Alarm contact	Shunt release	Auxiliary contact	Shunt release and auxiliary contact	Two groups of auxiliary contacts	Shunt release and alarm contact	Auxiliary contact and alarm contact	Shunt release, auxiliary contact and alarm contact	Two groups of auxiliary contacts, alarm contact
Over current release type	Code									
Instantaneous release	200	208	210	220	240	260	218	228	248	268
Duplex release	300	308	310	320	340	360	318	328	348	368

Note: As per power/load wiring mode, E, F type for 3P; G, H, I type for 4P

HUM8PV

Photovoltaic moulded case circuit breaker

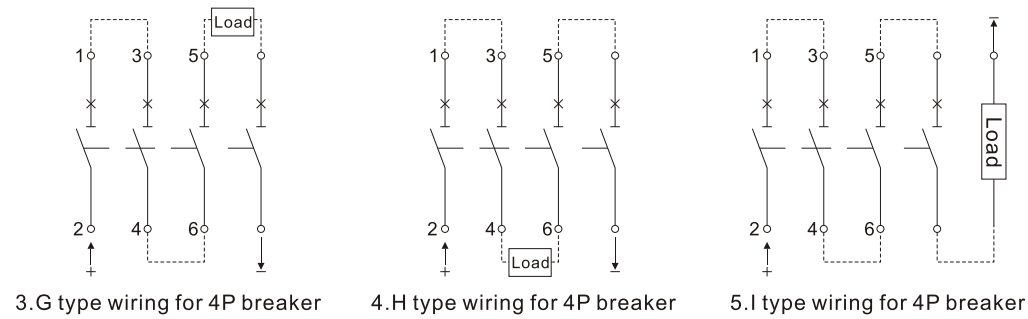
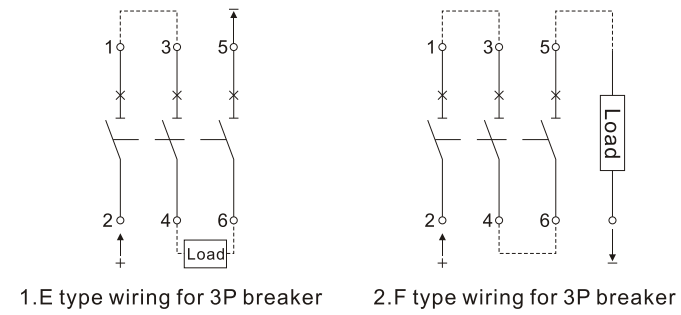

Power systems for above wiring mode please check sheet 2.
Sheet. 2

	To earth insulation system	Negative grounding system	Neutral point grounding system
DC500V	E	E、F	-
DC750V	E、H	F、G、I	H
DC1000V	H	I	H

4. Main technical parameters

Sheet. 3

Frame size rated current	125		250		400		630	
Rated current In(A)	16、20、25、32、40、50、63、80、100、125		100、125、160、180、200、225、250		225、250、315、350、400		400、500、630	
Pole number	3	4	3	4	3	4	3	4
Rated insulation voltage Ui (V)	1000							
Rated impulse withstand voltage Uimp(V)	8000							
Rated working voltage Ue (V)	DC 500 DC 750	DC 750 DC 1000	DC 500 DC 750	DC 750 DC 1000	DC 500 DC 750	DC 750 DC 1000	DC 500 DC 750	DC 750 DC 1000
Using category	A							
Rated limit/service short circuit breaking capacity Icu/Ics(kA)	DC500	15/15		65/65		65/65		65/65
	DC750	5/5	15/15	40/20	50/50	40/20	50/50	40/20
	DC1000		5/5		40/20		40/20	40/20
Flashover distance (mm)	≤50		≤50		≤100		≤100	
Operation performance (times)	Energized	5000		5000		1000		1000
	Non-energized	10000		10000		5000		5000

HUM8PV

Photovoltaic moulded case circuit breaker

5. Protection characteristics curve

1. HUM8PV-125 current temperature protection characteristics curve

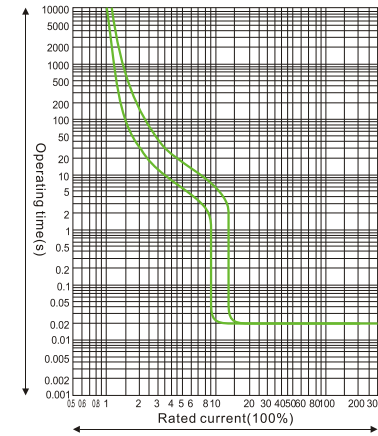

2. HUM8PV-250 current temperature protection characteristics curve

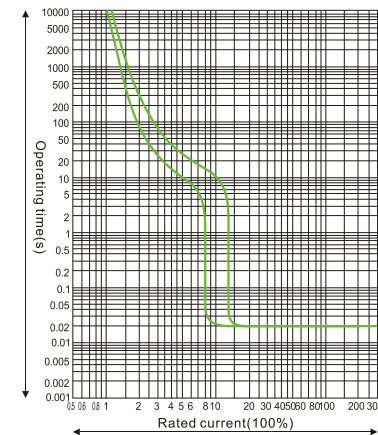

3. HUM8PV-400 current temperature protection characteristics curve

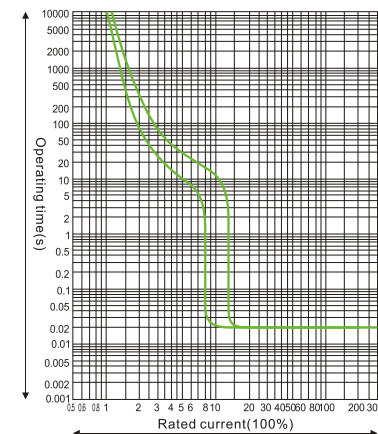

HUM8PV

Photovoltaic moulded case circuit breaker

4. HUM8PV-690 current temperature protection characteristics curve

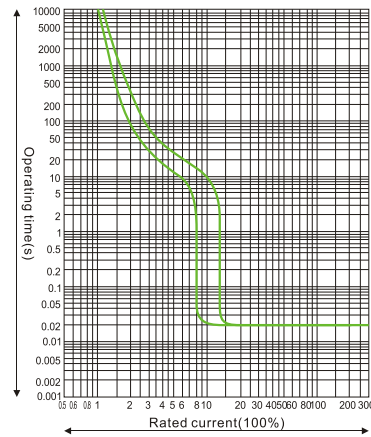

5. The temperature reducing capacity coefficient at different temperature.

	10°C	20°C	30°C	40°C	50°C	60°C	70°C
HUM8PV-125	1.15In	1.11In	1.15In	1In	0.93In	0.85In	0.8In
HUM8PV-250	1.15In	1.11In	1.15In	1In	0.93In	0.85In	0.79In
HUM8PV-400	1.16In	1.11In	1.15In	1In	0.94In	0.86In	0.81In
HUM8PV-630	1.17In	1.11In	1.15In	1In	0.9In	0.8In	0.7In

6. The reducing capacity coefficient in high altitude : when the altitude exceeds 2000m, the circuit breaker should be adjusted as sheet 4 Sheet. 4

Altitude(m)	2000	3000	4000	5000
Power frequency withstand voltage	3000	2500	2000	1800
Working current adjustment coefficient	1	0.94	0.88	0.83

7. DC system application: the following aspects should be considered before choose breaker in DC system.

- a. rated operation voltage, considering cascaded pole number
- b. rated current, considering load power
- c. breaking capacity, considering maximum short circuit current at mounting site
- d. Grounding system mode, see sheet 5

Sheet. 5

System type	Grounding system		Ungrounding system	
All kinds of fault types				
Failure effect	Failure I	Generate maximum short circuit current Contact connecting to positive pole break	U/2 voltage produce maximum short circuit current Contact connecting to negative pole break	No effect
	Failure II	Generate maximum short circuit current All the cascaded contacts break	Generate maximum short circuit current All the cascaded contacts break	Generate maximum short circuit current All the cascaded contacts break
	Failure III	No effect	Same as failure I But only for contact connecting to negative pole	No effect
The worst situation	Failure I	Failure I and Failure II	Failure II	
Breaking situation	Cascade in positive pole and break together	For each pole, break maximum short circuit current when U/2	Two poles break together	

HUM8PV

Photovoltaic moulded case circuit breaker

6. Overall and mounting size

1. E type wiring for 3P HUM8PV-125 (front connection)

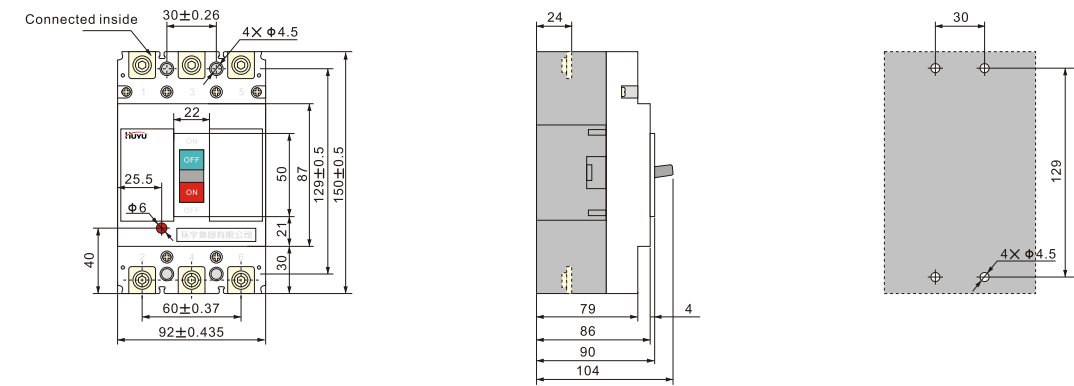

2. H type wiring for 4P HUM8PV-125 (front connection)

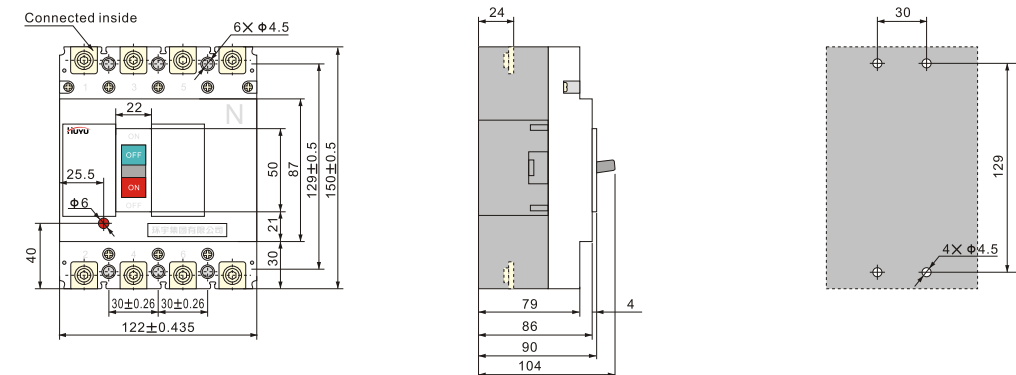

3. E type wiring for 3P HUM8PV-250 (front connection)

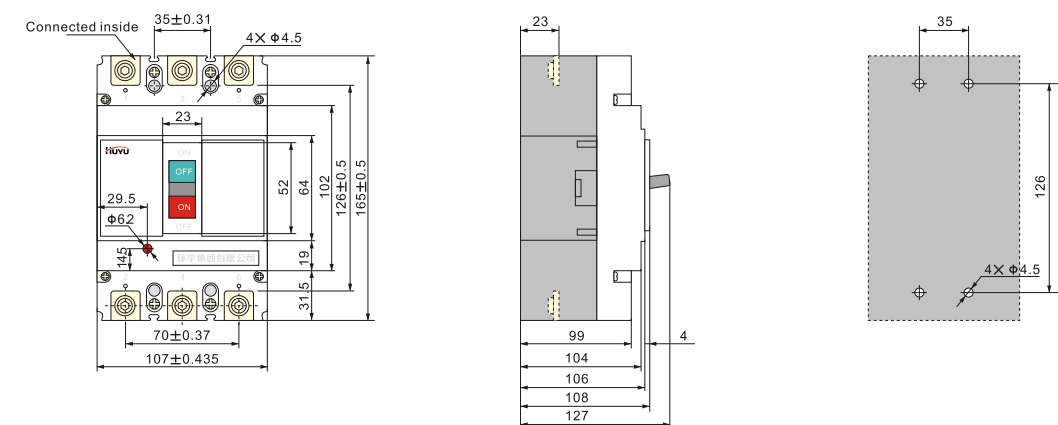

HUM8PV

Photovoltaic moulded case circuit breaker

4. H type wiring for 4P HUM8PV-250 (front connection)

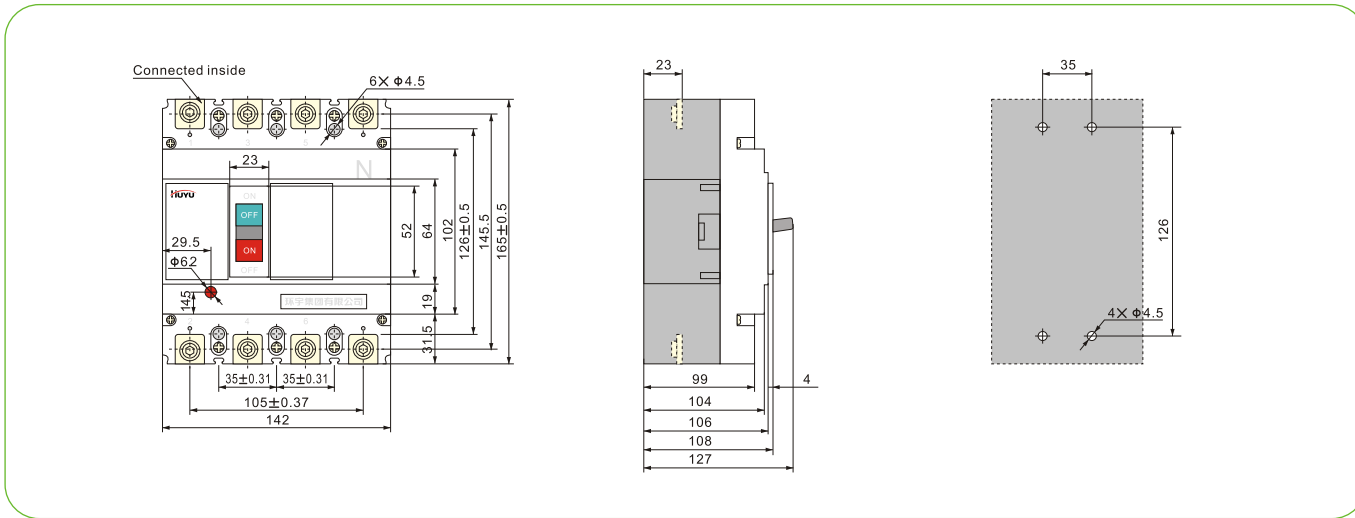

5. E type wiring for 3P HUM8PV-400 (front connection)

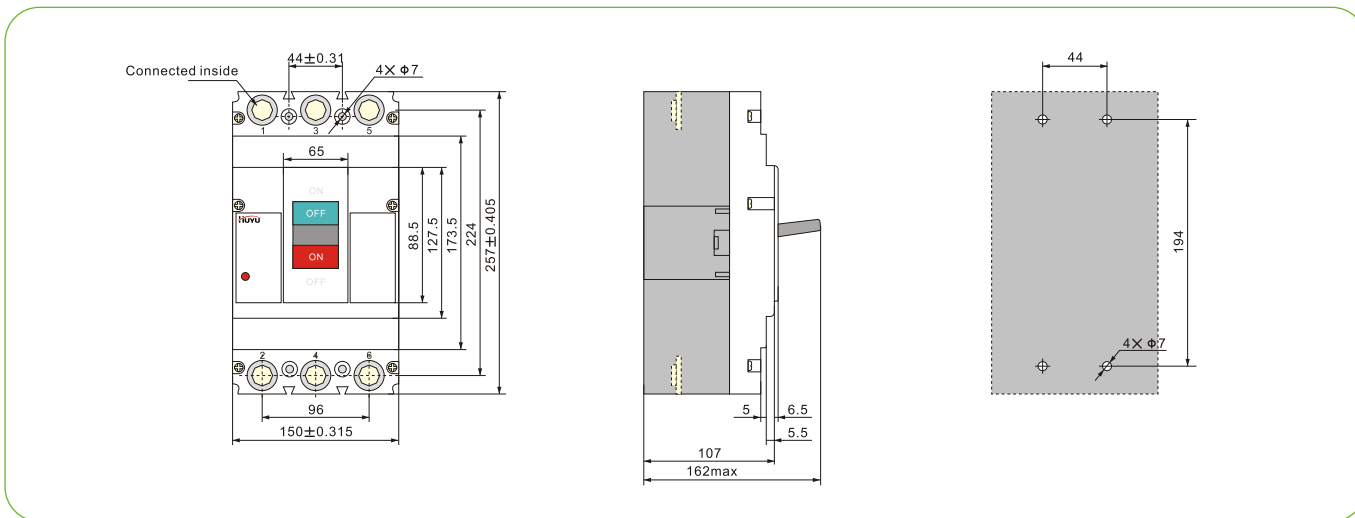

6. H type wiring for 4P HUM8PV-400 (front connection)

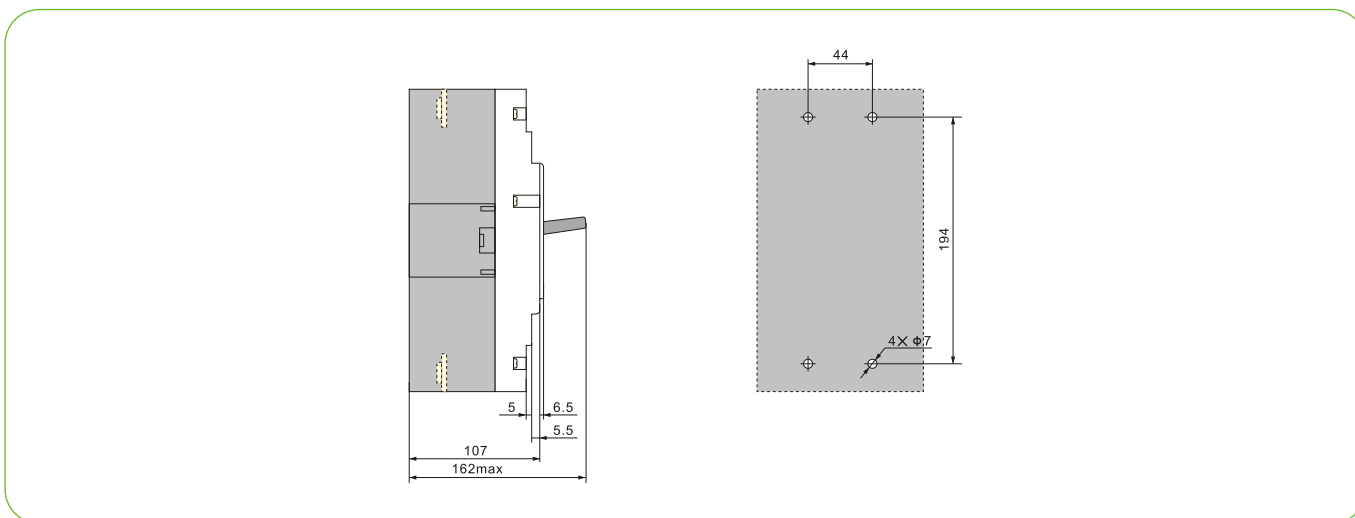

HUM8PV

Photovoltaic moulded case circuit breaker

7. E type wiring for 3P HUM8PV-630 (front connection)

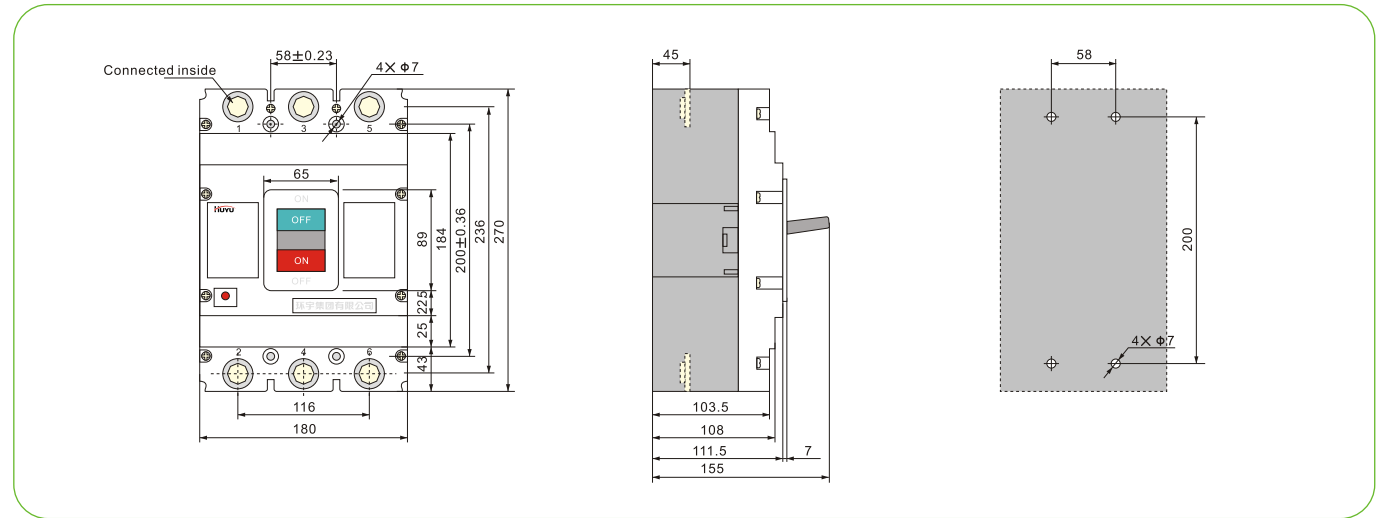

8. H type wiring for 4P HUM8PV-630 (front connection)

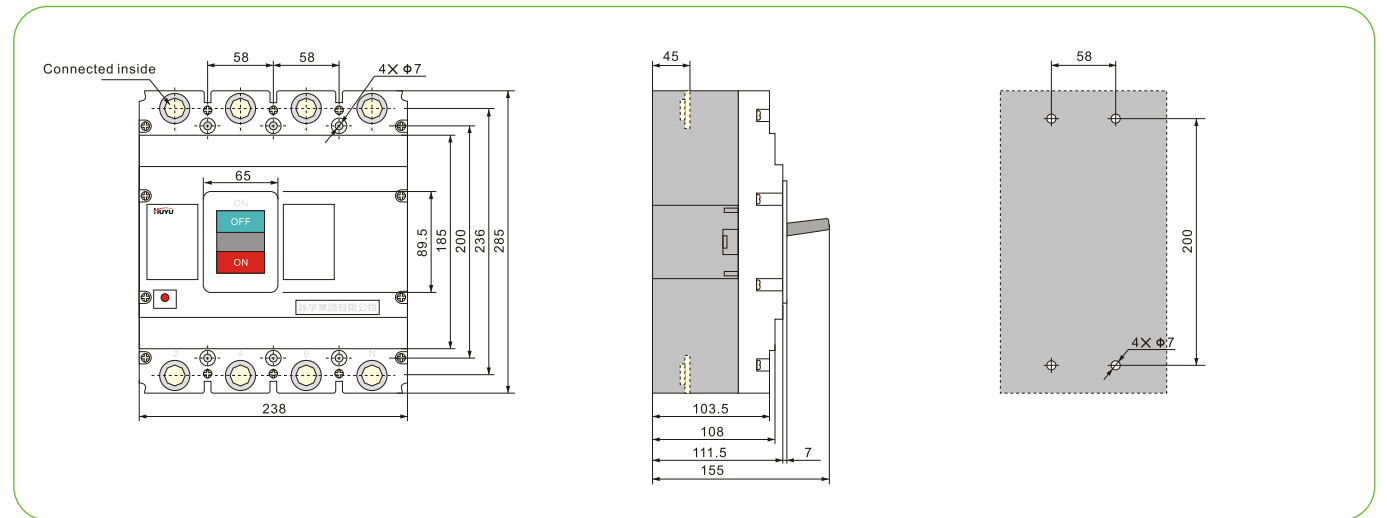

7. Accessories

1. Accessories can be provided as per user's requirement.

2. Shunt release parameters:

Rated voltage Us: AC230V, 400V; DC 220-250V, 24-30V

Breaker can reliably break at (70%-110%) Us, and action time is 10ms-30ms.

Note: when uses DC24V-30V shunt release, the maximum length of copper line should meet the requirements of sheet 6.

Sheet. 6

Rated control power voltage Us (DC24V~30V)	Input power	Maximum length of copper line	
		1.5 mm ²	2.5 mm ²
100%Us	50W	150m	250m
85%Us	50W	100m	160m

3. Rated value of auxiliary contact and alarm contact:

Conventional thermal current I_{th}=3A; rated working current I_e=0.79A(AC230V); I_e=0.47A(AC 400V); I_e=0.15A(DC250V)

HUM8PV Photovoltaic moulded case circuit breaker

4. Parameters of motor operation mechanism see sheet 7, total height of motor operation mechanism see sheet 8. The following is the wiring diagram of motor operation mechanism
Sheet.7 Parameters of motor operation mechanism

Frame size rated current Ie(A)	Rated working voltage Ue(V)	Starting current (A)	Action time (s)	Rated operation frequency (times/h)	Mechanical life (times)
125	AC 110V~230V 50Hz DC 110V~220V	≤0.5	≤0.8	180	9000
250					
400		≤2	120	5000	
630					3000

The power capacity of motor operation mechanism should be large enough to ensure the voltage impacted on at starting current should be no less than 85%Ue
Sheet . 8 Total height of motor operation mechanism.

Model	HUM8PV-125	HUM8PV-250	HUM8PV-400	HUM8PV-630
Height	170	199	230	246

Wiring diagram of motor operation mechanism

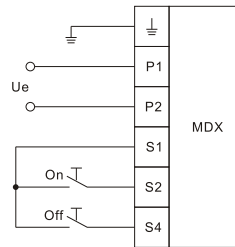

5. Mounting size of rotating handle operation mechanism see sheet 9
Sheet. 9

Model	HUM8PV-125	HUM8PV-250	HUM8PV-400	HUM8PV-630
Mounting size(H)	54	54	76	83

Overall and mounting hole drawing of A type (square) handle

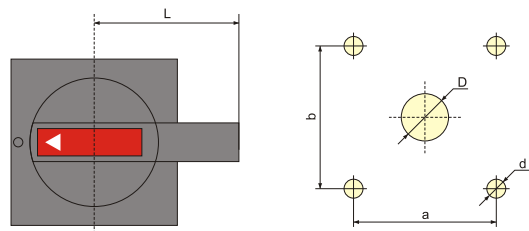

Model and specification	A1	A2
D	Φ42	Φ63
d	Φ4.5	Φ5.5
a	65	88
b	65	88
L	60	140

Overall and mounting hole drawing of B type (round) handle

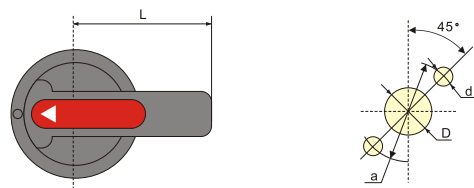

Model and specification	B1	B2	B3
D	Φ33	Φ33	Φ33
d	Φ4.5	Φ4.5	Φ4.5
a	Φ53	Φ53	Φ53
L	65	125	95

HUM8PV Photovoltaic moulded case circuit breaker

Overall and mounting sizes of centralized rotating handle operation mechanism

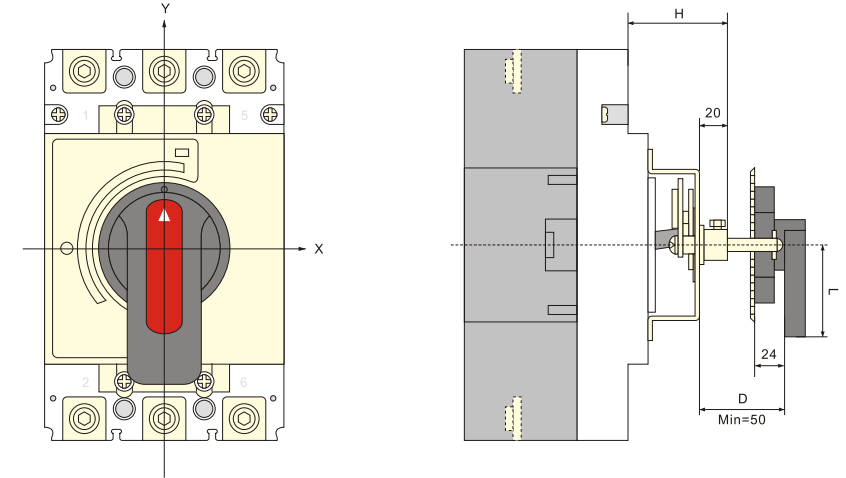

8. Installation and maintenance

1. Matters need attention before installation:

- Appearance shall be well and no-loaded action normal; rated value of breaker and accessories should conform to working conditions at mounting site; no obvious shock at mounting site and conform to normal working conditions
- Insulation test should be taken before ex-factory. Use 1000V DC MΩ meter to do retest before installation, among poles of circuit breaker, the insulating resistance between the same pole entering and outlet terminal should be no less than 20MΩ at breaking state.
- Cross section area of conductors should exceed the size regulated in sheet10, and the connection bolt should be screwed up.
- Characteristic of breaker and accessories should meet our order requirements.
- The breaker handle can turn to "on" , "off" , "trip" position, when it's "trip" , the handle rotated to "off" direction, then it can do "on" operation.
- Before add the internal accessories, the breaker tripper should be switch off.

Sheet. 10

Rated current(A)	10	16、20	25	32	40、50	63	80	100	125	160	180、200、225	250	315、350	400
Line cross section area	1.5	2.5	4	6	10	16	25	35	50	70	95	120	185	240

Sheet. 11

Rated current (A)	Cable cross section area		Copper bar size	
	Quantity	Cross section area(mm ²)	Quantity	Size(mmXmm)
500	2	150	2	30X5
630	2	185	2	40X5

9. Ordering information

- Product name and model
- Rated current, release type, instantaneous release setting current multiple
- Accessories name and specification