



HYET3 Series Three-section Type PC-level Automatic Transfer Switching Equipment

Installation and Operation Instruction

Please read the instruction carefully before installing and using the product, and keep it for future reference.

Product Certificate

This product has passed the inspection and meets the requirements of GB/T14048.11, and therefore is allowed to leave the factory.



Inspector:

Date of inspection:

See the product or packaging.

HUANYU HIGH-TECH CO., LTD.

HYET3 Series Three-section Type Instruction

Safety Notification

Please read the instruction carefully before the installation, handling, operation, maintenance and inspection, and install and use this product accurately according to the contents in the instruction.



Danger:

- Do not operate the automatic transfer switching equipment with wet hands;
- Do not touch the conductive parts in use;
- Ensure that the product is not charged during maintenance;
- Do not test the product by short circuit



Attention:

- Installation, maintenance and service shall be carried out by qualified personnel;
- Please confirm whether the working voltage, rated current, frequency and characteristics of the product meet the working requirements before use;
- The product parameters shall be adjusted according to the product instruction and the on-site usage;
- If the manual operation is required during maintenance, you must enter the manual mode and use the matching handle;
- If it's required to test the insulation resistance or power frequency withstand voltage, you must first disconnect the electronic elements (including the controller) between the current circuits;
- In the cases of product damage or abnormal voice when unpacking, stop using the product immediately and contact the supplier;
- When the product is scrapped, please dispose of the product waste properly. Thank you for your cooperation.



Test:

- The insulation test specified in the standard has already been performed for the automatic transfer switching equipment before leaving the factory, which doesn't need to be performed again.

I. Product Overview

- The HYET3 Automatic Transfer Switching Equipment (hereinafter referred to as “switch”) is a switch that can continue to supply the power in an emergency. The switch consists of a load switch (ATSE without fuse or current tripping) and an intelligent controller. With the latest microcomputer control system as the core, it adopts electromagnetic compatibility design, which has strong anti-interference and can be stable and reliable during long-term continuous work. Equipped with LED/LCD display, it can provide users with friendly human-machine interface, simple operation, obvious warning and high intelligence, which is an ideal mechatronic new automatic transfer switching equipment.
- This product complies with GB/T 14048.11-2016 *Low-voltage Switchgear and Controlgear — Part 6-1: Multiple Function Equipment: Automatic Transfer Switching Equipment*

II. Scope of Application

- This switch is suitable for 50/60 Hz automatic transfer switching equipment with rated voltage below AC 400 V and rated current below 1,600 A. The switch can realize automatic or manual transfer between common (I) power supply and standby (II) power supply. The main or standby power supply can be power grid, generator or storage battery, etc., which is determined by the user. When the state of the switch is automatically transferred, unattended automatic operation can be realized. This switch is suitable for users with special or first-class load specified by the state, such as high-rise buildings, posts and telecommunications, coal mines and ships, industrial assembly lines, healthcare, military equipment, airports, fire control, metallurgy, chemical industry, textiles, petroleum and other important places where power failure is not allowed.

III. Normal Operating Conditions

- The ambient temperature shall be $-5^{\circ}\text{C} \sim +40^{\circ}\text{C}$, and the average temperature within 24 hours shall not exceed $+35^{\circ}\text{C}$. The relative humidity at the highest temperature of $+40^{\circ}\text{C}$ shall not exceed 50%, and a higher relative humidity is allowed at a lower temperature. For example, 90% humidity at $+20^{\circ}\text{C}$, but condensation may occur due to temperature change, which shall be considered.
- The altitude of the installation location shall not exceed 2,000 m, and the category shall be Class IV.
- The inclination shall not be more than $\pm 23^{\circ}\text{C}$.
- The contamination grade shall be Grade 3.
- If the above conditions cannot be met, please consult the manufacturer when ordering.

IV. Model Description

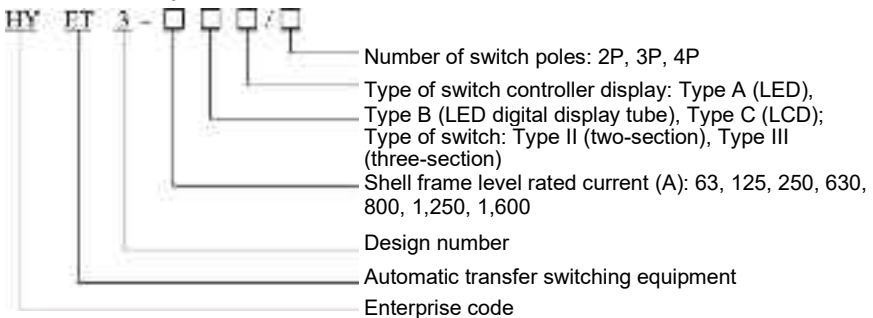

V. Structural Features and Functions

- For the HYET3 (main and standby) Automatic Transfer Switching Equipment, the switch is driven electromagnetically, the main circuit contacts are of dynamic and static structures, and the moving contacts are of V-shape design. Due to its superior structure, it can be interlocked electrically and mechanically at the same time, thus ensuring that the main and standby power supplies will not be

switched on at the same time, and that the common and standby power supplies work reliably and do not interfere with each other. The control power supply of the switch is from the AC 220 V main and standby power supplies (without additional control current), which has a remarkable energy-saving effect. The switch has electrical and mechanical closing instructions, and it can also provide customers with normally open and normally closed passive contacts for other purposes.

- The intelligent controller simultaneously provides many functions such as voltage loss, undervoltage, overvoltage, transfer delay control, generator signal control, and feedback signal, and has strong anti-interference ability.
- It has three transfer modes including automatic charge and automatic recovery, automatic charge without automatic recovery, and mutual standby.
- The three-section switch has three stable working positions: common power supply closing-standby power supply opening, common power supply opening-standby power supply opening, and common power supply opening-standby power supply closing.
- Simple and convenient installation.
- Manual transfer can be carried out with special handle in the manual state.

VI. Three-section Product Manual Operation Method

- Common (I) power supply input method: Press the "Two-way Power Off" button first, and then press it down in place with the handle according to the direction indicated by the arrow on the nameplate. The common (I) switch status window on the right shows ON, which is the common (I) power input.
- Standby (II) power supply input method: Press the "Two-way Power Off" button first, and then press and hold the "Pilot Standby Power Supply" button, and press it down in the direction indicated by the arrow on the nameplate with the handle at the same time, and the standby (II) switch status window on the right shows ON, which is the standby (II) power input.
- The handle must be operated in the direction indicated by the arrow "Handle Operation Direction" on the nameplate. Reverse operation is strictly prohibited.
- Note: Do not operate manually with the handle when the switch is in the automatic state.

VII. Technical Parameters

Name		Model	HYET3 -63	HYET3 -125	HYET3 -250	HYET3 -630	HYET3 -800	HYET3 -1250	HYET3 -1600	
Use category			AC-33B					AC-33iB		
Rated working voltage U_e			AC 230 V(2P)/AC 400 V(3P/4P)			AC 400 V				
Rated insulation voltage U_i			AC 800 V							
Rated impact withstand voltage U_{imp}			AC 8 kV							
Rated limited short-circuit current I_a			100kA			120 kA				
Service life	Mechanical		6,000	6,000	6,000	6,000	6,000	6,000	5,000	
	Electrical		1,500	1,500	1,500	1,500	500	500	500	
Number of poles			2	2	2	/	/	/	/	
			3	3	3	3	3	3	3	
			4	4	4	4	4	4	4	
Operation cycle (sec/time)			30 s	30 s	30 s	30 s	60 s	60 s	60 s	
Switching time			0-255 s							

VIII. Three-section Switch Outline and Installation Dimensions

8.1 Outline and installation dimensions of HYET3-63~630AF Switch

8.1.1 Type A and B outline and installation dimensions

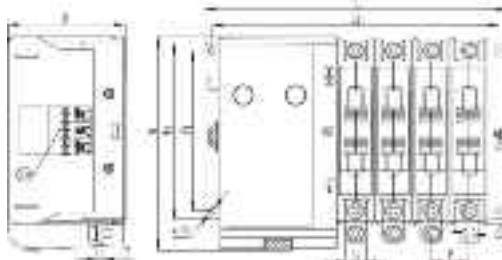

Model & Specification	Size		Outline dimension				Installation dimension					Copper bar dimension			
	L			W	W2	H	L1			W1	4-Φ	L2	T	P	Φ
	2P	3P	4P				2P	3P	4P						
HYET3- 63IIIA/B	196	220	244	203	168	112	182	206	230	152	7	12	2	24	6.5
HYET3-125IIIA/B	206	236	266	203	168	112	192	222	252	152	7	15	2.5	30	8.5
HYET3-250IIIA/B	218	254	290	203	168	112	204	240	276	152	7	20	4	36	8.5
HYET3-630IIIA/B	297	357	417	284	226	138	276	336	396	206	9	40	5	60	13

8.1.2 Type C outline and installation dimensions

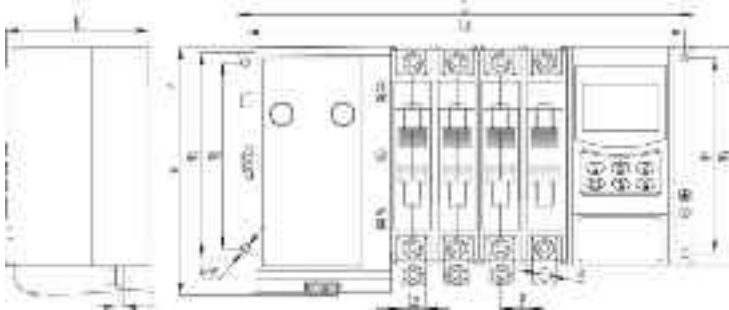

Model & Specification	Size		Outline dimension				Installation dimension					Copper bar dimension					
	L			W	W2	W4	H	L1			W1	W3	4-Φ	L2	T	P	Φ
	2P	3P	4P					2P	3P	4P							
HYET3-63IIIC	282	306	330	203	168	170	118	268	292	316	152	152	7	12	2	24	6.5
HYET3-125IIIC	292	322	352	203	168	170	118	278	308	338	152	152	7	15	2.5	30	8.5
HYET3-250IIIC	304	340	376	203	168	170	118	290	326	362	152	152	7	20	4	36	8.5
HYET3-630IIIC	388	449	510	284	226	226	143	368	429	490	206	206	9	40	5	60	13

8.2 Outline and installation dimensions of the HYET3-800~1600AF Switch

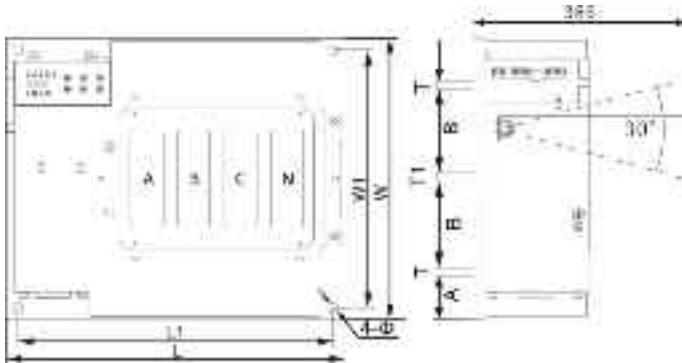

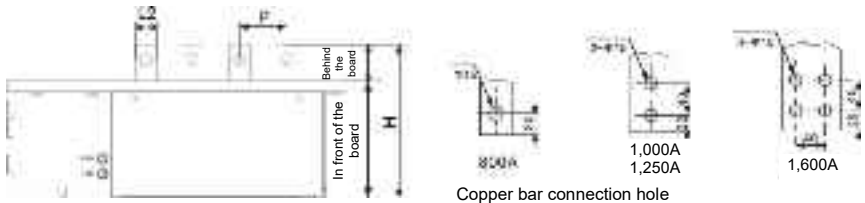

Copper bar connection hole dimensions

Model & Specification	Size		Outline dimension				Installation dimension				Copper bar dimension						
	L		W		H		L1		4-Φ		In front of the board		Behind the board		P		
	3P	4P	W	H	3P	4P	W1	4-Φ	In front of the board	Behind the board	A	B	L2	T	T1	A-B phase C-N phase	B-C phase
HYET3-800AF	405	470	390	210	373	438	358	14	164	50	60	117	30	12	15	65	65
HYET3-1250AF	450	530	390	250	418	498	358	14	164	90	58	117	50	12	15	80	80
HYET3-1600AF	509	610	390	255	477	578	358	14	164	95	55	117	75	15	15	101	101

8.3 Outline and installation dimensions of the HYET3-63~1600AF/C split controller



Controller mounting hole: 130*75

IX. Three-section Switch Structure and Function Description of Controller Keys and Indicator Lights

9.1 HYET3-63~630AF/A, B, C

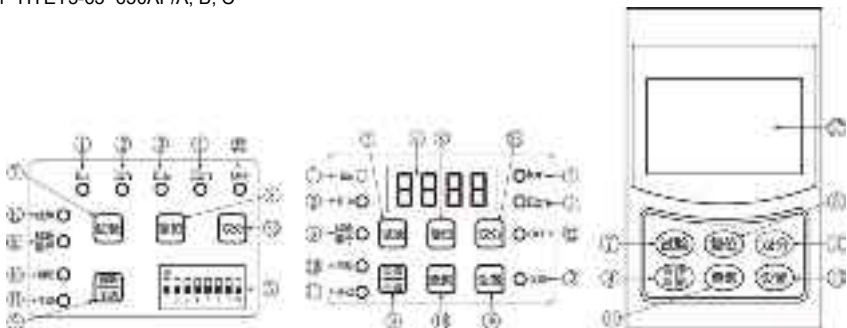

Type A Controller

Type B Controller

Type C Controller

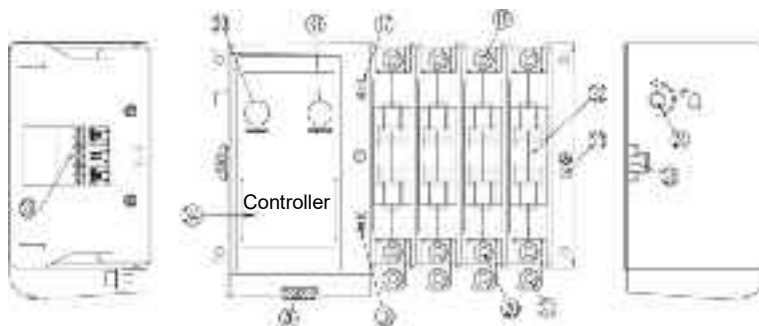

Structure of Type A and B switches

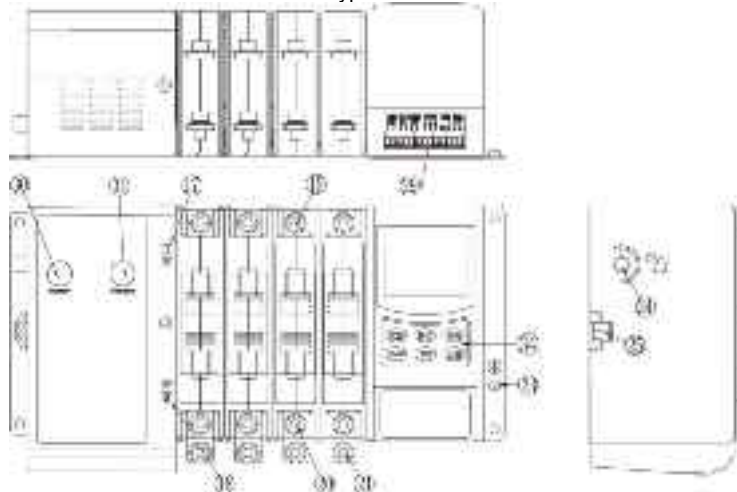

Structure of Type C switches

9.2 HYET3-800~1600AF/A, B, C

Type A Controller

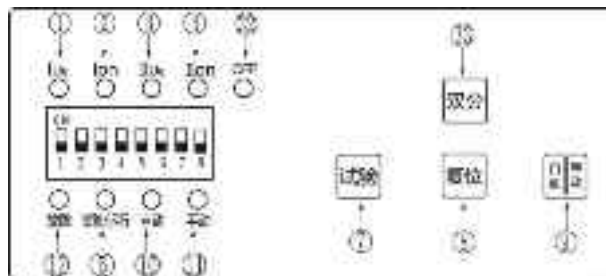

Type B Controller

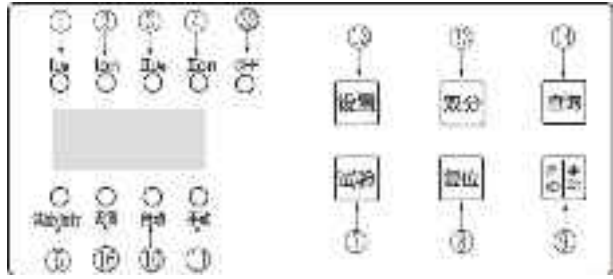

Type C Controller

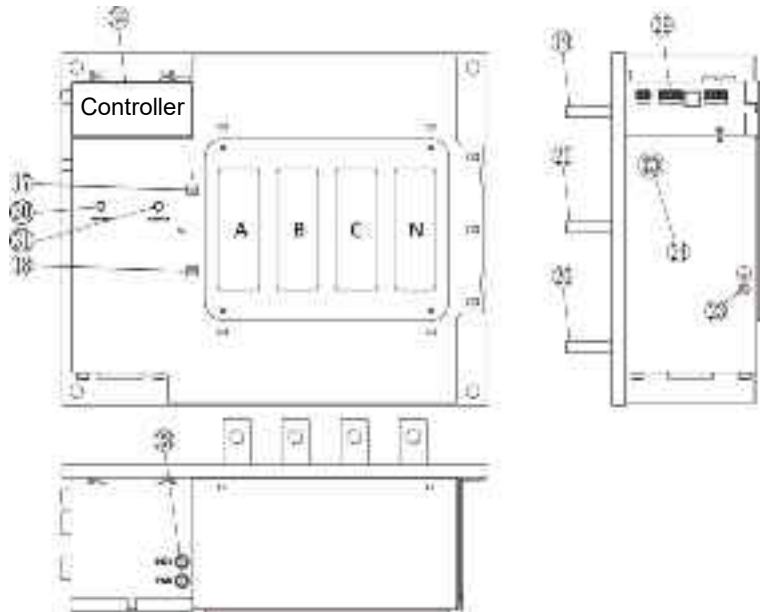
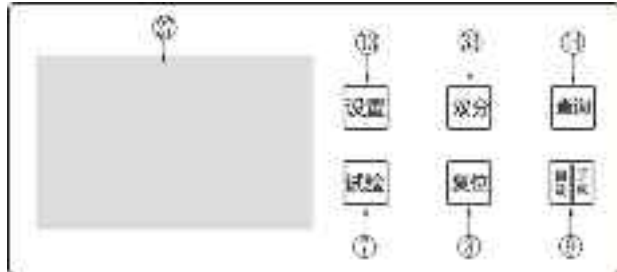

- ⑥ Dip switch ⑮ Digital display tube ⑰ Common (I) power supply opening/closing indicator window ⑱ Standby (II) power supply opening/closing indicator window ⑲ Common(I) power supply incoming port ⑳ Standby (II) power supply incoming port ㉑ Load outgoing port ㉒ Arc-extinguishing chamber ㉓ Grounding screw ㉔ Handle operating shaft ㉕ 3P neutral wire access terminal ㉖ LCD (liquid crystal display) ㉗ Fuse ㉘

User external port indicator ⑳ “Two-way Power Off” button ㉑ “Pilot Standby Power” button ㉒ Controller

9.3 ㉓ Description of signal and fire control function of Type A and B generators



9.3.1 OFF Vin DC24V: 1#, 2# wiring port fire control input DC 24 V (regardless of positive and negative poles)

9.3.2 Signals of the generator: 3# wiring port: NC, the normally closed terminal of the generator

4# wiring port: COM, the public terminal of the generator

5# wiring port: NO, the normally open terminal of the generator

9.4 Function description of Type A panel indicator light

① I_{ue}: Common (I) power indication; (I) power supply is normal when the indicator light is normally on, and (I) power supply fails when the indicator light flashes;

② I_{on}: Common (I) power supply closing instruction;

③ II_{ue}: Standby (II) power indication; (II) power supply is normal when the indicator light is normally on, and (II) power supply fails when the indicator light flashes;

④ II_{on}: Standby (II) power supply closing instruction;

⑤ Operation/Test indicator light: Normally on light indicates that the switch operates under the automatic control; Flashing light indicates that the switch is in the test transfer state;

⑩ Automatic indicator light is on: The switch operates in the automatic control working mode of the controller;

⑪ Manual indicator is on: The switch operates in manual (manual handle) operation mode;

⑫ Fault indicator light: Normally on light indicates that the switch transfer fails (the switch is not in the same position as the controller, and the switch cannot be transferred normally);

㉓ OFF: Dual-split indicator light. The indicator light normally on indicates that the switch is in the dual-split position, and the two power supplies are disconnected;

9.5 Function description of Type A panel keys (II)

⑥ DIP switch: Set the transfer mode and the transfer delay time;

⑦ Test key: Press the test key each time to perform the test transfer between the common (I) power supply and the standby (II) power supply, and the (operation/test) indicator light on the switch panel flashes;

⑧ Reset key: In the test transfer function state, press the reset key to restore the switch to the automatic operation transfer state, and the (operation/test) indicator light does not flash;

⑨ Manual/automatic key: Press the (manual/automatic) key each time to select the working mode of the controller, and the corresponding working mode (manual/automatic) indicator light on the switch panel lights up.

㉓ Dual-split key: Press the dual-split key to transfer the switch to the dual-split position, the two power supplies are disconnected, and the corresponding OFF indicator light on the switch panel lights up.

9.6 Function description of Type B panel indicator light

① I_{ue}: Common (I) power indication; (I) power supply is normal when the indicator light is normally on, and (I) power supply fails when the indicator light flashes;

② I_{on}: Common (I) power supply closing instruction;

③ II_{ue}: Standby (II) power indication; (II) power supply is normal when the indicator light is normally on, and (II) power supply fails when the indicator light flashes;

④ II_{on}: Standby (II) power supply closing instruction;

⑤ Operation/Test indicator light: Normally on light indicates that the switch operates under the automatic control; Flashing light indicates that the switch is in the test transfer state;

⑩ Automatic indicator light is on: The switch operates in the automatic control working mode of the controller;

⑪ Manual indicator is on: The switch operates in manual (manual handle) operation mode;

⑬ Setting indicator light: The indicator lights up when the controller is in the setting state.

㉓ OFF: Dual-split indicator light. The indicator light normally on indicates that the switch is in the dual-split position, and the two power supplies are disconnected.

Transfer fault indication: "" symbol displayed on the digital display tube indicates that the switch transfer fails (the switch is not in the same position as the controller, and the switch cannot be transferred normally).

9.7 Function description of Type B panel keys

- ⑦ Test key: Press the test key each time to perform the test transfer between the common (I) power supply and the standby (II) power supply, and the (operation/test) indicator light on the switch panel flashes;
- ⑧ Reset key: In the test transfer function state, press the reset key to restore the switch to the automatic operation transfer state, and the (operation/test) indicator light does not flash; (It is used as the state reset in the normal state and saved as the setting parameter in the setting state)
- ⑨ Manual/automatic (+) key: Press the (manual/automatic) key each time to select the working mode of the controller, and the corresponding working mode (manual/automatic) indicator light on the switch panel lights up. (It is used as the manual or automatic working mode in the normal state, and used as the function key to increase setting parameters in the setting state.)
- ⑬ Setting key: Enter the function setting of the controller, and the setting indicator light on the switch panel lights up in the setting state;
- ⑭ Inquiry (-) key: It is used as inquiry in the normal state (and used as the function key to decrease setting parameters in the setting state);
- ⑬ Dual-split key: Press the dual-split key to transfer the switch to the dual-split position, the two power supplies are disconnected, and the corresponding OFF indicator light on the switch panel lights up.

9.8 Function description of Type C panel keys

- ⑦ Test key: Press the test key each time to perform the test transfer between the common (I) power supply and the standby (II) power supply, and the word "Test" is displayed in the working status bar on the LCD screen;
- ⑧ In the test transfer function state, press the reset key to restore the switch to the automatic operation transfer state. (It is used as the state reset in the normal state and saved as the setting parameter in the setting state)
- ⑨ Manual/automatic key (+): Press the (manual/automatic) key each time to select the working mode of the controller, and the word "Manual/Automatic" is displayed in the working status bar on the LCD screen; (It is used as the manual or automatic working mode in the normal state, and used as the "Add" function key to set parameters in the setting state.)
- ⑬ Setting key: Enter the function setting of the controller;
- ⑭ Inquiry key (-): It is used as inquiry in the normal state (and used as the "Minus" function key to set parameters in the setting state);
- ⑬ Dual-split key: Press the dual-split key to transfer the switch to the dual-split position, the two power supplies are disconnected, and the word "Dual-split" in the working status bar is displayed on the LCD screen.

9.9 Parameter description of Type C LCD panel

Ia 220V	IIa 220V
Ib 220V	IIb 220V
Ic 220V	IIc 220V
Working state:	Manual
Switch position:	I Closed

- 9.9.1 Ia Ib Ic: Common power supply voltage indication. The numbers refer to the detected voltages of A, B, C phases respectively.
- 9.9.2 IIa IIb IIc: Standby power supply voltage indication. The numbers refer to the detected voltages of A, B, C phases respectively.
- 9.9.3 Switch state: Display the switch state.
 - (1) "Manual" means that the switch operates in the manual (manual handle) operation mode.
 - (2) "Automatic" means that the switch is automatically controlled by the controller.
 - (3) "Test" means that the switch is in the test transfer state.
 - (4) "Dual-split" means the switch is in the dual-split position, and the two power supplies are disconnected.
 - (5) "Fire Control" means that DC 24 V voltage is continuously input to the user's external fire control function port, and the switch is in the dual-split position, and the two power supplies are disconnected.
- 9.9.4 Switch position: Display the switch closing position and transfer fault.
 - (1) "(I) Closed" refers to common (I) power supply closing.
 - (2) "(II) Closed" refers to standby (II) power supply closing.
 - (3) "Dual-split" means the switch is in the dual-split position.
 - (4) When "ERROR" is displayed, it means that the switch transfer fails, that is, the switch and the controller are not in the same position, and the switch cannot be transferred normally.

9.10 Description of user external port

9.10.1 ② HYET3-63~630AF/A, B user external ports

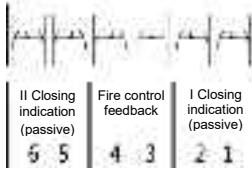

- 1, 2 wiring ports: Common (I) power supply closing instruction, passive contact output
- 3, 4 wiring ports: Fire control feedback signal (passive contact output)
- 5, 6 wiring ports: Standby (II) power supply closing instruction, passive contact output

9.10.2 ② HYET3-63~630AF/C user external ports

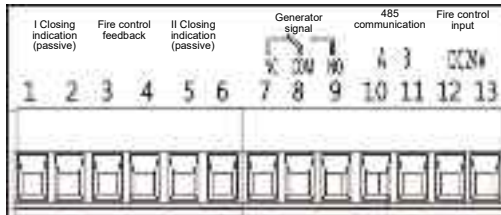

- 1, 2 wiring ports: Common (I) power supply closing instruction, passive contact output
- 3, 4 wiring ports: Fire control feedback signal (passive contact output)
- 5, 6 wiring ports: Standby (II) power supply closing instruction, passive contact output
- 7, 8, 9 wiring ports: Generator signal: NC, normally closed wiring port of the generator
COM: Common wiring port of the generator
NO: Normally open wiring port of the generator

10, 11 wiring ports: 485 communication A, B

12, 13 wiring ports: Fire control input DC 24 V (regardless of positive and negative poles)

9.10.3 ② HYET3-800~1600AF/A, B user external ports

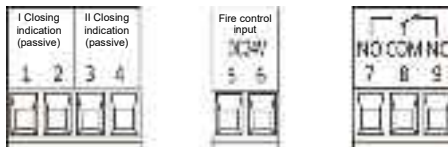

- 1, 2 wiring ports: Common (I) power supply closing instruction, passive contact output
- 3, 4 wiring ports: Standby (II) power supply closing instruction, passive contact output
- 5, 6 wiring ports: Fire control input DC 24 V (regardless of positive and negative poles)
- 7, 8, 9 wiring ports: Generator signal: NC, normally closed wiring port of the generator
COM: Common wiring port of the generator
NO: Normally open wiring port of the generator

9.10.4 ② HYET3-800~1600AF/C user external ports

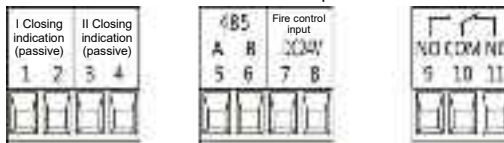

- 1, 2 wiring ports: Common (I) power supply closing instruction, passive contact output
- 3, 4 wiring ports: Standby (II) power supply closing instruction, passive contact output
- 5, 6 wiring ports: 485 communication A, B

7, 8 wiring ports: Fire control input DC 24 V (regardless of positive and negative poles)
 9, 10, 11 wiring ports: Generator signal: NC, normally closed wiring port of the generator
 COM: Common wiring port of the generator
 NO: Normally open wiring port of the generator

X. Three-section Controller Function Parameter Setting and Query

10.1 Function description of the controller:

Controller	Type A	Type B	Type C
Working electric source of controller	AC220V		
Manual control	Provided		
Transfer mode	Automatic charge and automatic recovery, and automatic charge without automatic recovery		Automatic charge and automatic recovery, automatic charge without automatic recovery, and mutual standby
Power supply monitoring: Voltage loss, undervoltage and overvoltage	Common: Phases A, B, C; standby: Phase A		Common: Phases A, B, C; standby: Phases A, B, C
Transfer delay	Fault confirmation delay: 0-5 s Transient residence time: 0-90 s Return delay: 0-5 s	Fault confirmation delay: 0-90 s Transient residence time: 0-99 s Return delay: 0-90 s	Fault confirmation delay: 0-90 s Transient residence time: 0-255 s Return delay: 0-90 s
Generator signal	Passive contacts: one opened and one closed		
485 communication	---		Provided

10.2 Parameter setting of controllers

10.2.1 Parameter setting of the Type A controller

		DIP switch function details							
Fault	1	OFF	OFF	ON	ON				
	2	OFF	ON	OFF	ON				
Confirmation delay	Duration	1s	3s	5s	0s				
	3	OFF	OFF	OFF	OFF	ON	ON	ON	ON
Transient residence time	4	OFF	OFF	ON	ON	OFF	OFF	ON	ON
	5	OFF	ON	OFF	ON	OFF	ON	OFF	ON
	Duration	3s	5s	10s	20s	30s	60s	90s	0s
Return confirmation delay	6	OFF	OFF	ON	ON				
	7	OFF	ON	OFF	ON				
	Duration	1s	3s	5s	0s				
Transfer mode settings	8	OFF				ON			
	Mode	Automatic charge and automatic recovery				Automatic charge without automatic recovery			

10.2.2 Parameter setting of the Type B controller

- Press the "Set" key to enter the setting menu.
- Press the "Set" key to select the functional parameters to be changed.
- Press "+/-" key to modify this function data. If other functional parameters need to be reset, repeat steps 2-3.
- Press the "Reset" key to save the data and exit the setting interface. Before the setting process data is saved, set the timeout exit time to 30 s. If no system key operation is performed within 30 s, the system will automatically exit the setting according to the timeout operation, and will not save the parameters set this time.

10.2.3 Parameter setting of the Type C controller:

- Press and hold the "Set" key for 3 s to enter the setting interface.
- Press the "+/-" key to select the setting parameters to be changed.
- Press the "Set" key to enter this function parameter setting.
- Press "+/-" key to modify the data.

- (5) Press the "Set" key to exit this functional parameter setting. If other functional parameters need to be reset, repeat steps 2–5.
- (6) Press the "Reset" key to save the data and exit the setting interface. Before the setting process data is saved, set the timeout exit time to 30 s. If no system key operation is performed within 30 s, the system will automatically exit the setting according to the timeout operation, and will not save the parameters set this time.

Type B code	Functions	Setting range			Factory value		
		Type A	Type B	Type C	Type A	Type B	Type C
H	Overvoltage	265 V, nonadjustable	250 V–300 V, adjustable		265V		
H	Undervoltage	170 V, nonadjustable	130 V–200 V, adjustable		170V		
1E	Fault confirmation delay (Type C: T1)	The settings below can be available: 0 s/1 s/3 s/5 s	0 s–90 s, adjustable		1		
2E	Transient residence time (Type C: T2)	The settings below can be available: 0 s/3 s/5 s/10 s/20 s/30 s/60 s/90 s	0 s–99 s, adjustable	0 s–255 s, adjustable	3s		
3E	Return confirmation delay (Type C: T3)	The settings below can be available: 0 s/1 s/3 s/5 s	0 s–90 s, adjustable		1s		
FF	Transfer mode	The 8th digit of the DIP switch: OFF means automatic charge and automatic recovery ON means automatic charge without automatic recovery	0 means automatic charge and automatic recovery 1 means automatic charge without automatic recovery	Automatic charge and automatic recovery Automatic charge without automatic recovery Mutual standby	OFF	0	Automatic charge and automatic recovery

10.3 Parameter query of the controller

When patrolling the parameters set by the controller, the user can directly press the query key on the panel to check the set parameters without entering the system settings.

10.3.1 Type B displays the parameters (as shown in the table below) in turn by pressing the query key each time. You can press the reset key to terminate the query, and will automatically exit the query interface if you stay in the query state beyond 3 seconds.

10.3.2 Type C displays the parameters (as shown in the table below) by pressing the query key. You can press the reset key again to terminate the query, and will automatically exit the query interface if you stay in the query state beyond 30 seconds.

Function description		Display of Type B digital display tube		Display of Type C controller LCD	
Measured dynamic value	Iue indicator light is on	Phase A voltage of common (I) power supply	H	220 V	You can perform query without entering the LCD home page of the query interface, and see 9.9.1 and 9.9.2 for details
		Phase B voltage of common (I) power supply	b	220 V	
		Phase C voltage of common (I) power supply	l	220 V	
	IIue indicator light is on	Phase A voltage of standby (II) power supply	A.	220 V	
		Phase B voltage of standby (II) power supply	/	/	
		Phase C voltage of standby (II) power supply	/	/	
Controller program setting parameters	Overvoltage	U	265 V	Overvoltage: 265 V	
	Undervoltage	A	170V	Undervoltage: 170 V	
Controller program setting parameters	Fault confirmation delay	1E	1s	T1: 1s	
	Transient residence time	2E	3s	T2: 3s	
	Return confirmation delay	3E	1s	T3: 1s	
	Transfer mode	FF	0	Transfer mode: Automatic charge and automatic recovery	

XI. Considerations in Use and Maintenance

- This product can work reliably at 85%–110% rated working voltage.
- When installing and wiring the product, the user shall pay strict attention to the N-pole sign at the incoming and outgoing line terminals (the neutral wire shall be connected to the neutral wire terminal for the three-pole product). The neutral wire of the four-pole product shall not be shared, and the product shall be well grounded to ensure the safety of power supply and use.
- Check whether the contact parts of all electrical appliances are reliable and pressed, and whether the fuses are in good condition.
- After the power is turned on, the user can set the system based on the needs, and can also put it into use according to the factory default value of the product.
- After the above installation and commissioning, put the controller system in the "Automatic" state and put it into use: When the switch needs to be transferred manually, the controller system shall be placed in the "Manual" state before the manual operation can be carried out with the special handle provided with the product.
- During the use of the product, a general inspection shall be conducted regularly (for example, every three months), and the transfer power supply shall be tested once to check whether the product is running normally.
- In general maintenance or repair of the product, it is necessary to ensure that the product is not charged. After the maintenance and repair, restore the dual power controller to the automatic state.

XII. Transfer Fault Analysis and Elimination

External environmental conditions	No-transfer fault	Cause for no-transfer fault	Fault elimination
The common power supply is abnormal, and the switch is not transferred to the standby power supply side	The manual light is on	The switch is in the manual state	Press the manual and automatic keys to make the switch in the automatic state
	The test/operation light flashes	The switch is in the test state	Press the reset key
	The lue light is not on, and no standby voltage is provided; Type C II voltage loss	The standby incoming line has no power supply	Check the incoming line power supply
		The incoming wire is not connected to the neutral wire	Connect the neutral wire
		The incoming screw is not tightened	Tighten the screw
	The lue light flashes, and the standby power supply fails; Type C II overvoltage and undervoltage	The overvoltage protection/program setting overvoltage protection value is too low	1. Check the incoming line power supply 2. Reset the program overvoltage and undervoltage protection values 3. Connect the neutral wire
		The undervoltage protection/program setting overvoltage protection value is too high	
The above conditions are normal	The incoming wire is not connected to the neutral wire	Adjust the transfer delay time	
	The setting transfer delay time is too long The fuse is blown	Replace the fuse	
The common power supply returns to normal, and the switch does not transfer from the standby power supply side to the common power supply side	The manual light is on	The switch is in the manual state	Press the manual and automatic keys to make the switch in the automatic state
The common power supply returns to normal, and the switch does not transfer from the standby power supply side to the common power supply side	The test/operation light flashes	The switch is in the test state	Press the reset key
	The lue light is not on, and no common voltage is provided; Type C I voltage loss	The common incoming wire has no power supply	Check the incoming line power supply
		The incoming wire is not connected to the neutral wire	Connect the neutral wire
		The incoming screw is not tightened	Tighten the screw
	The lue light flashes, and the common power supply fails; Type C I overvoltage and undervoltage	The overvoltage protection/program setting overvoltage protection value is too low	1. Check the incoming line power supply 2. Reset the program overvoltage and undervoltage protection values
The undervoltage protection/program setting overvoltage protection value is too high			

External environmental conditions	No-transfer fault	Cause for no-transfer fault	Fault elimination
		The incoming wire is not connected to the neutral wire	3. Connect the neutral wire
	The above conditions are normal	The transfer mode is set to automatic charge without automatic recovery and mutual standby	Reset the transfer mode Set the mode to automatic charge and automatic recovery
		The setting transfer delay time is too long	Adjust the transfer delay time
		The fuse is blown	Replace the fuse
	In summary, if the switch fails to transfer normally due to the above reasons, notify the after-sales service personnel of the supplier or replace the switch.		
	If the fault light is on, Type B digital display tube displays  , or Type C LCD interface displays ERROR, and the normal transfer cannot be performed by pressing the reset key, inform the after-sales service personnel of the supplier or replace the switch.		

XIII. Company Commitment

On the premise that users abide by the use and storage conditions and the product seals are intact, if the product is damaged or cannot be used normally due to manufacturing quality problems within 24 months from the production date of the product, the company will be responsible for the repairing or replacement free of charge. If the warranty period expires, users shall pay the repair. However, if the damage is caused by the following circumstances, the fees for repair shall still be charged even within the warranty period:

- (1) Improper use, maintenance and safekeeping.
 - (2) Self-modification and improper maintenance.
 - (3) Damage caused by falling and installation after purchase.
 - (4) Force majeure such as earthquake, fire, lightning stroke, abnormal voltage and secondary disasters.
- In case of any questions, please contact the dealer or our customer service department.

**Address: Wenzhou Bridge Industrial
Zone, Yueqing City, Zhejiang Province**
Service hotline: 400-887-5757
Switchboard: 0577-62889999
Fax: 0577-62885588
Website: www.huyu.com.cn